

PIT MASTER

LED LIGHTING TOWERS



6HTM1500 LED LIGHTING TOWER SPECIFICATIONS

FEATURES

- ✓ Over 50 – 70% reduction in fuel consumption
- ✓ Refuel every 3 weeks (LED 4 head)
- ✓ Extra low voltage (Electrocution risk eliminated)
- ✓ Immediate light start up
- ✓ Reduction in running & maintenance costs
- ✓ 50,000 hour light life
- ✓ 500 hour service intervals (Additional Option)

SPECIFICATIONS

| | |
|-------------------------------|--|
| Lights | LED 4 – 2 x Spot 2 x Flood LED 6 – 4 x Spot 2 x Flood |
| Light Output | LED 4 – 160,000 Lumens (1,080W) LED 6 – 240,000 Lumens (1,620W) |
| Tower Voltage | 24VDC |
| Alternator | 4 Pole Direct Drive |
| Engine | Kubota Z482 |
| Fuel Capacity | 140 L (36.98 gal) |
| Fuel Tank Hours | LED 4 - 233 Hours LED 6 - 175 Hours |
| Wheel Size | 4 x 4 Rims Off Road Tyres 195/70/R14 |
| Total Weight (No Fuel) | 1,100 kg (2,425 lbs) |
| Boom | Hydraulic Lift/Extension |
| Boom Rotation | Manual Rotation |
| Legs | Manual Pull Out and Pin Lock |

MEASUREMENTS

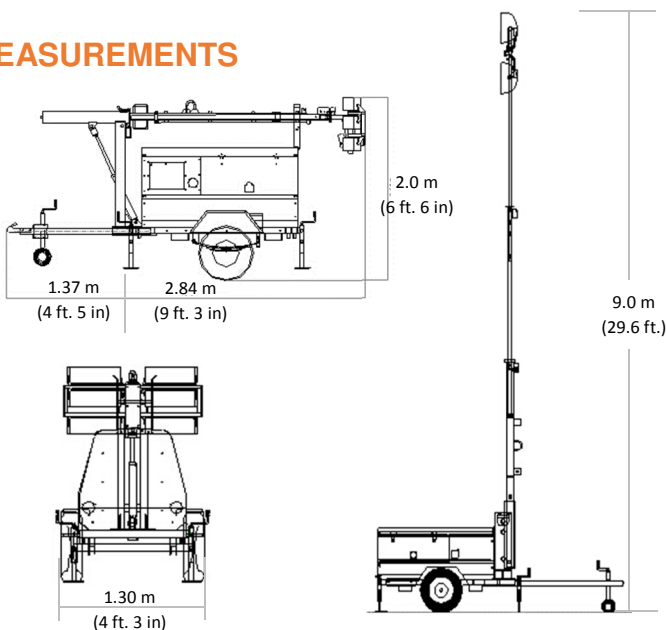

STANDARD INCLUSIONS

| | |
|--------------------------|--|
| Engine Protection | Fail Safe Shutdown – Temp, Oil & Water |
| Battery Isolation | Standard Inclusion |
| E-Stop | Standard Inclusion |
| Controls | Manual Key and Gauges |
| Wheel Chocks | Standard Inclusion |

ENGINE OPTIONS

| | |
|--------------------------|--|
| Engine Upgrade | Kubota D1105 |
| Engine Alternator | 30 Amp Alternator Upgrade (If Fitting HV Inverter) |
| Radiator | Mine Spec Radiator Cap |
| Service Upgrade | 500 Hour Service Sump 500 Hour Service Kit (Fuel & Oil Filters) |

TOWER OPTIONS

| | |
|--------------------------|--|
| Controller | Electronic Sunight Auto Start/Stop |
| Warning Light | Amber LED Warning Beacon |
| Fuel Warning | Red Fuel Warning LED Beacon |
| Battery Isolation | Mine Spec Double Pole with Lockout |
| Start Isolation | Mine Spec Single Pole with Lock Out |
| Jump Start | Cat or Anderson Plug |
| Internal Lighting | Internal Work Light with Switch |
| Fire Extinguisher | 4.5 kg (9.9 lb) Standard |
| Wheels | Spare Wheel & Carrier Wheel Nut Indicators |
| HV Power | HV Inverter and Specified Plug (Requires Alternator Upgrade) |
| Cold Weather Pack | Battery Blanket, Engine Block & Coolant |



1013 Obici Industrial Blvd. Suffolk VA. 23434
 Office Phone: 757-925-2899
 Email: peverett@grandwattelectric.com
www.grandwattelectric.com
www.pitmaster.com.au

